



**QCA
for
Cables**

For an immediate quote,
email sales@qcamfg.com
or call 408.441.1001

■ Custom Cables and Harnesses

■ Serving Computer, Telecom, Medical, and many other industries

■ Voice, Data, Video, Coax, Shielded, Flat Ribbon, Dsub, Power applications

■ NPI through Volume Production Design Services

■ Documentation Support

■ Value Add Services for Fans, Motors

■ JIT and Kanban

■ Build to Order (BTO)

■ Configure to Order (CTO)

■ Direct Order Fulfillment

■ Offshore Capabilities

■ Cable Kits

■ RoHS Compliant Ready

In today's competitive market, every efficiency is needed to survive and excel. By partnering with QCA, we can work together to understand your cable and harness requirements, recommend solutions and provide a quality product that meets and even exceeds your expectations.

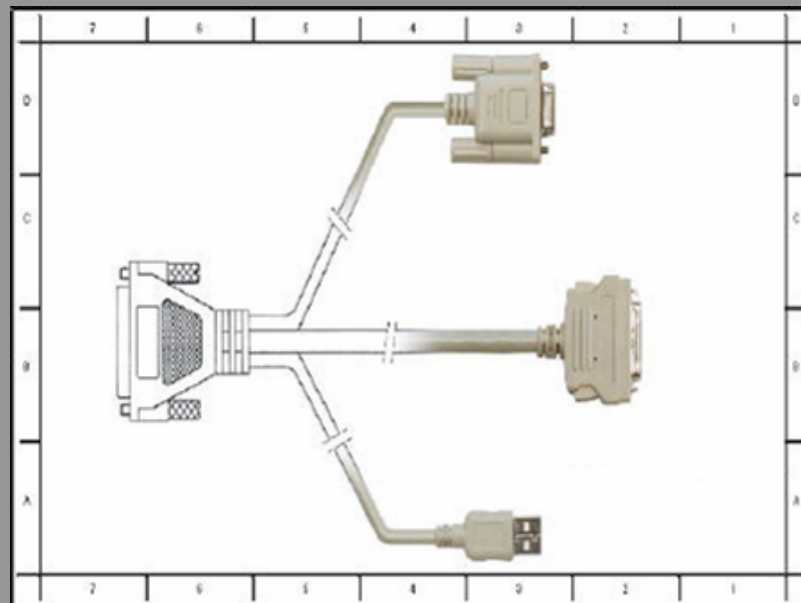

QCA is equipped to accommodate your cable and wire harness requirements from product design and development through prototype and full production. We carefully manage every step of the manufacturing process resulting in unsurpassed quality and the highest level of customer satisfaction.

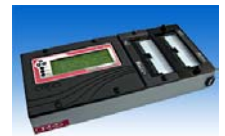

Q Quality
Circuit
Assembly

1709 Junction Court, Unit 380
San Jose, CA 95112
408.441.1001 Telephone 408.441.0301 Fax
www.qcamfg.com